

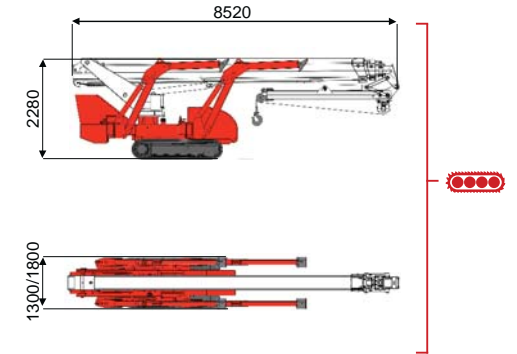

42 m ↑  
16 m →  
500 Kg ⚙️

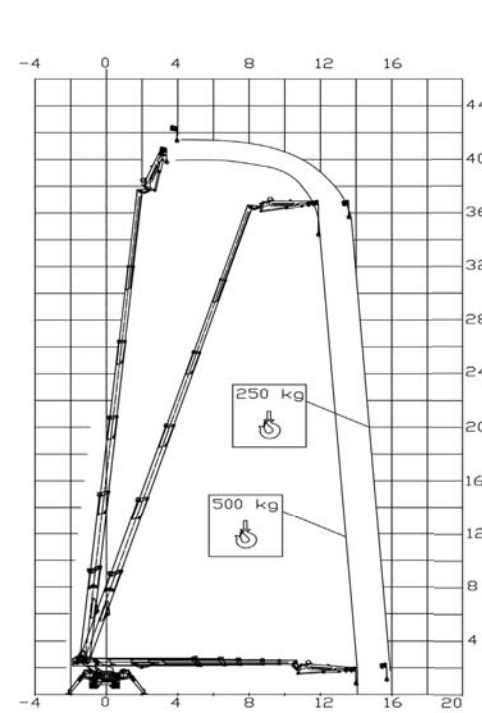

BI-ENERGY  
Diesel+AC



XTJ 43/C-R		42 m	16 m	500 kg	660°	5,33 m	25%	40%	2,25 km/h	10900 kg	75 kN	4,06 kN/m <sup>2</sup>	5,33 kN/m <sup>2</sup>	1350/1800 mm	8520 mm	2280 mm
------------	--	------	------	--------	------	--------	-----	-----	-----------	----------	-------	------------------------	------------------------	--------------	---------	---------



Battery type



Battery charge



Add. Weight



Autonomy



Charging time

Electropump

ECO	DC+AC		48V 270 A/h 5h		230V-48V 45A		400 kg		6-7 h endless		7h					
-----	-------	--	----------------	--	--------------	--	--------	--	---------------	--	----	--	--	--	--	--

TCA Lifting Ltd  
Unit 4, Derby Dell Buildings, Lasham  
Hampshire. GU34 5RX United Kingdom  
Tel. (+44) 0845 603 5360  
info@tcalifting.com  
www.tcalifting.com

